

Technical Data Sheet

Specification

Customer Name: RealTech Controls

Customer P/N: RTC-LEDUV-3535-18M12V

Manufacturer P/N: GG-3535UVAC-2002

Date: May 1, 2020

<input type="checkbox"/> Technical Reference			<input type="checkbox"/> Sample			<input checked="" type="checkbox"/> Mass Product		
Customer approval				GM approval				
Approved	Audit	Confirmation	Approved	Audit	Confirmation			
<input type="checkbox"/> Qualified		<input type="checkbox"/> Disqualified		Date:				



ATTENTION
OBSERVE PRECAUTIONS
FOR HANDLING
ELECTROSTATIC
SENSITIVE DEVICES

Technical Data Sheet

■ Features :

- low voltage operation
- Instant light
- Long operating life

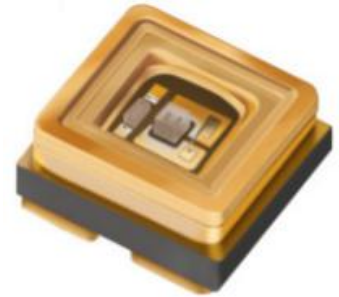

■ Applications :

- Disinfection sterilization
- Ultraviolet detection、 communication technology
- Air sterilization, water sterilization
- Medical treatment and skin disease treatment

Technical Data Sheet

■ Package Dimensions

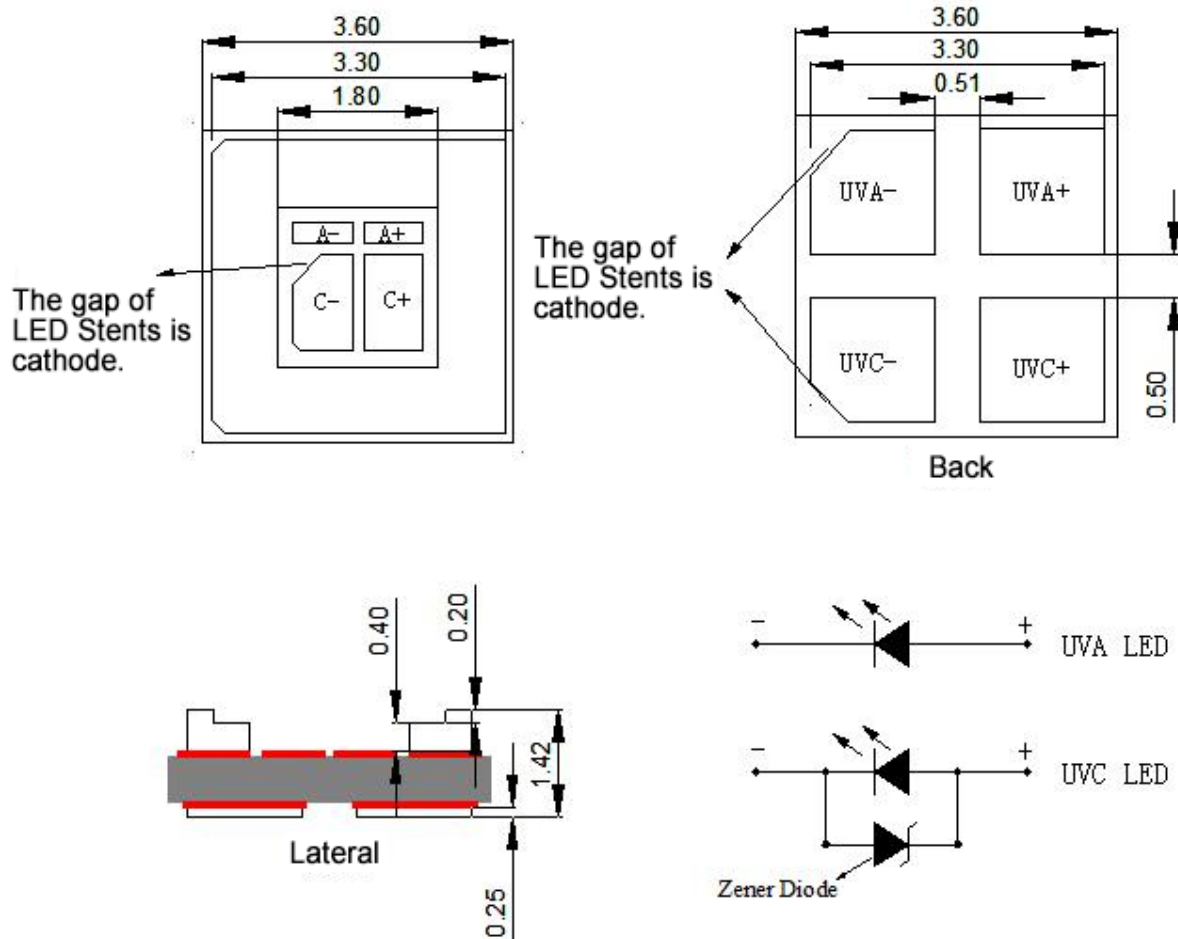

Notes:

1. All dimensions in mm tolerance ± 0.1 mm unless otherwise noted.
2. In addition to the UV LED chip, there is an additional zener diode welded in the device to provide ESD protection against electrostatic breakdown of the UV LED chip.

Technical Data Sheet

■ Absolute Maximum Ratings(At TA=25°C)

Parameter	Symbol	Rating	Unit
DC Forward Current UVC	I _F	70	m A
DC Forward Current UVA	I _F	60	m A
Peak pulse Current* UVC	I _{FP}	150	m A
Peak pulse Current* UVA	I _{FP}	120	m A
Power Dissipation UVC	P _D	0.5	W
Power Dissipation UVA	P _D	0.2	W
Operating Temperature Range	T _{OPR}	-30~+75	°C
Storage Temperature Range	T _{STG}	-40~+85	°C

Note:

1. 1/10 Duty cycle, 0.1ms pulse width.
2. Care is to be taken that power dissipation does not exceed the absolute maximum rating of the product.
3. When the LEDs are in operation the maximum current should be decided after measuring the package temperature, junction temperature should not exceed the maximum rate. LED

Technical Data Sheet

■ Electrical/Optical Characteristics-White(At T_A=25°C)

	Parameter	Symbol	Conditions	Min	Avg.	Max	Units
UVC	Forward Voltage	V _F	I _F =40mA	5.00	--	8.00	V
	Radiant Flux	Φ _e	I _F =40mA	2		4	mW
	Peak wavelength	λ _p	I _F =40mA	265		285	nm
	Viewing Angle ^[1]	2Θ _{1/2}	I _F =40mA	--	100	--	Deg
UVA	Forward Voltage	V _F	I _F =20mA	3.00	--	3.80	V
	Radiant Flux	Φ _e	I _F =20mA	20		60	mW
	Peak wavelength	λ _p	I _F =20mA	390		410	nm
	Viewing Angle ^[1]	2Θ _{1/2}	I _F =20mA	--	100	--	Deg

Note:

1. The above forward voltage measurement allowance tolerance is ±0.1V。
2. The tests shown above allow a tolerance of ±10%。
3. The wavelength measurement error shown above is plus or minus 0.1nm。
4. 2θ_{1/2} is the angle from optical centerline where the luminous intensity is 1/2 the optical centerline value。

Technical Data Sheet

■ Typical Optical/Electrical Characteristics Curves

($T_a=25^\circ\text{C}$ Unless Otherwise Noted)

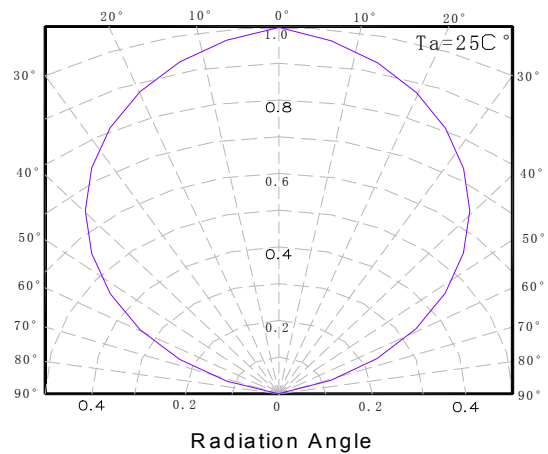
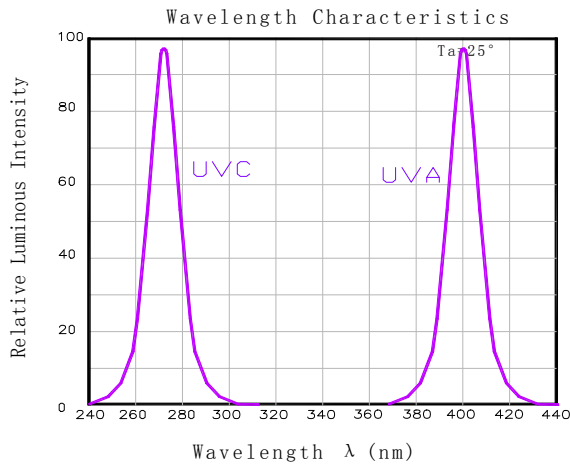
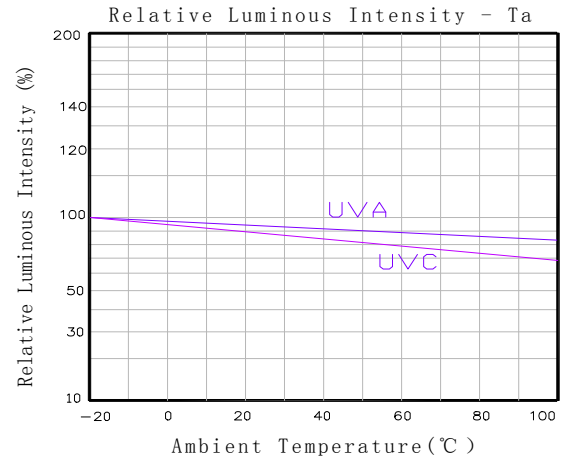
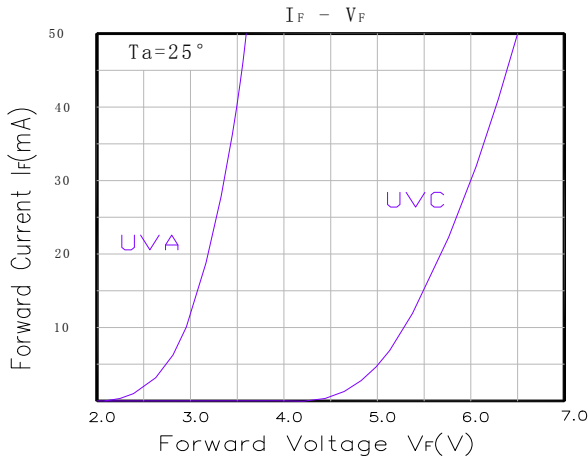
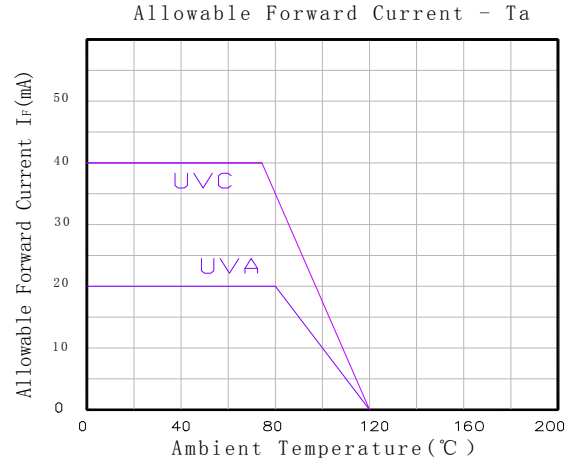
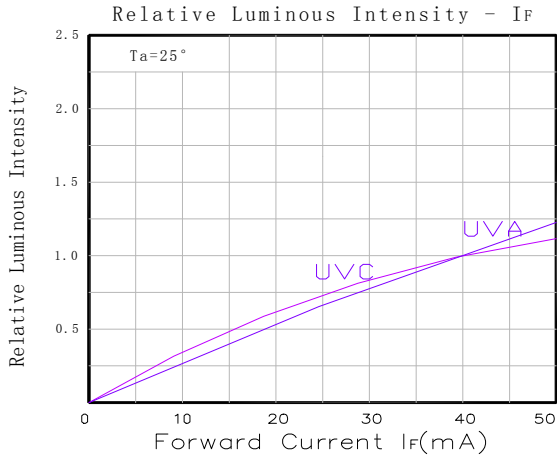

Technical Data Sheet

■ Reliability test standards

Test Item	REF. Standard	Test condition	Duration	Sample count	Accept
Temperature Cycle	JESD22-A104-A	100°C±5 30min~25°C 30min,5min,30min, 5m in	100 cycles	22	0/22
Thermal shock	JESD22-A106	-40°C~100°C 30min, 30min	100 cycles	22	0/22
High Temperature Storage	JEITA ED-4701 200 201	TA=100°C±5°C	1000 Hrs	22	0/22
Low Temperature Storage	JEITA ED-4701 200 202	TA=-40°C±5°C	1000 Hrs	22	0/22
Humidity Heat Storage	JIS C 7021 (1977)B-11	Ta=60°C RH=85%	1000Hrs	22	0/22
Life test	JESD22-A108-A	Ta=25°C If=40mA	1000Hrs	22	0/22
High humidity e at life test	JESD22-A101	Ta=60°C RH=85% IF=40mA	1000Hrs	22	0/22

Criteria For Judging Damage :

Test Item	Symbol	Test condition	Criteria For Judgement	
			Min.	Max.
Forward Voltage	VF	IF=40mA	--	U.S.L*)1.1
Reverse Current	IR	VR=5V	--	10uA
Luminous Flux	Lm	IF=40mA	L.S.L*)0.7	--
Lamp bead lighting test	/	IF=40mA		

U.S.L: Upper standard level

L.S.L: Lower standard level

Note :

The above technical data is only the typical value of the product, not as any application conditions and application mode guarantee.

Technical Data Sheet

■ SMT ReflowSoldering Instructions SMT

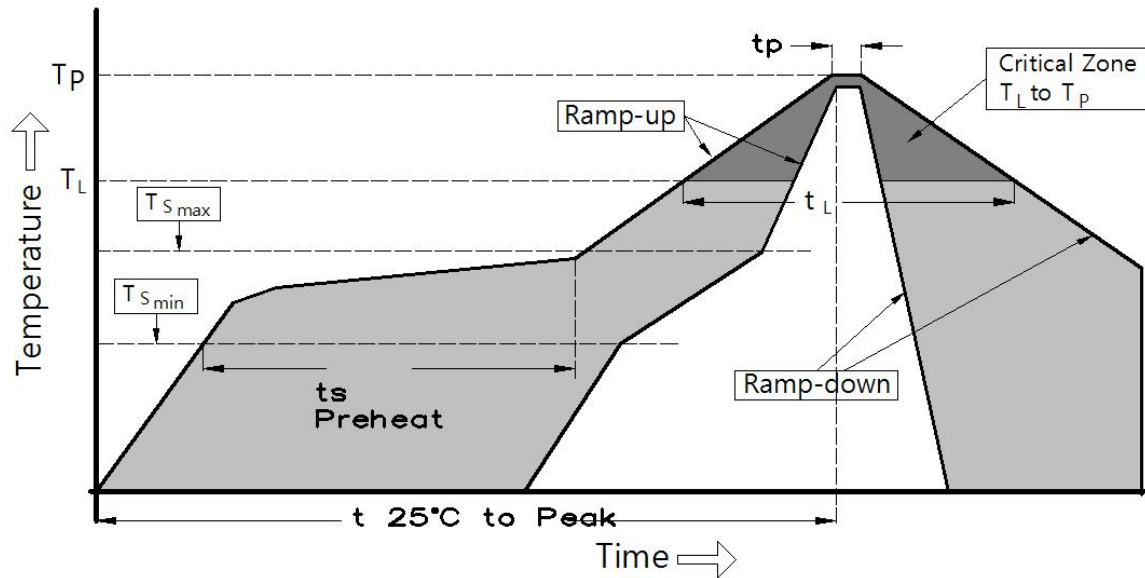

Average Temperature Rising Rate:	Maximum 3°C per second
Warm Up: Minimum Temperature:	100 °C
Warm Up: Maximum Temperature:	130 °C
Warm Up: Time($T_{s_{min}}$ to $T_{s_{max}}$):	60 - 120 Seconds
Maintain High Temp.for A Limited Time:	165 °C
Maintain High Temp.for A Limited Time:	Up to 60 Seconds
Peak Value/Classification Temperature:	180 °C
Peak Value/Classification Temperature for A Limited Time:	Up to 10 Seconds
Hold Time Within 5°C Lower Than Actual Peak Temperature (T_p):	Up to 30 Seconds
Cooling Rate	Maximum 6°C per second
Time Required To Rise To Peak Temperature At 25°C:	Up to 8 Minutes

●Notes for reflow [if reflow products are needed]

- 1.Reflow soldering should not be done more than two times. In the case of more than 24 hour s passed soldering after first, LEDs will be damaged.
- 2.When welding, do not press hard on the surface of the lens when the material is heated.

3.Scrape the heat-conducting solder paste on the aluminum base plate, stir the solder past e clockwise for 10-15 minutes before scraping the solder paste, and place the aluminum base pla te on the solder paste scraping tool. Scrape the solder paste evenly and thickly

Technical Data Sheet

4. Scrape solder paste steel mesh needs to be made into a cross, so as to allow air circulation, avoid solder paste lifting caused by LED poor heat dissipation

5. Note that the lamp should be installed flat and the two pins of the LED light source should be installed on the welding pad position of the aluminum substrate.

6. Scrape the aluminum base plate of solder paste in 2 hours to install all the light source, light source installed in the aluminum base plate, the operator should self-check whether the light source is installed (can't have reverse, light source bottom suspension) to tilt 45 degrees Angle to check each light source

7. After reflow welding, check whether the light source is in the position of the welding pad

, and do not have eccentric phenomenon, or the line will be broken in the second light distribution lens, resulting in open circuit.

8. Rapid cooling is not allowed after reflow soldering.

9. Do not weld on deformed PCB.

● Soldering Iron

1. When hand soldering, keep the temperature of iron below less 300°C less than 3 seconds.

2. The hand solder should be done only one time.

● Repairing

Repair should not be done after the LEDs have been soldered. When repairing is unavoidable, a double-head soldering iron should be used (as below figure). It should be confirmed in advance whether the characteristics of LEDs will or will not be damaged by repairing.

● Cautions

1. LED product is lens package, the surface is relatively brittle, pressing the lens surface will

It affect the LED reliability, so there should be preventive measures to avoid pressing the device, when using the nozzle, the pressure on the lens surface should be appropriate. LED

2. Components should not be mounted on warped (non coplanar) portion of PCB. After soldering, do not warp the circuit board. LED

3. Do not apply mechanical force or excess vibration during the cooling process to normal temperature after soldering. Do not rapidly cool device after soldering.

Technical Data Sheet

■ Packing Standard

Normal packing quantity: 1000pcs/rel

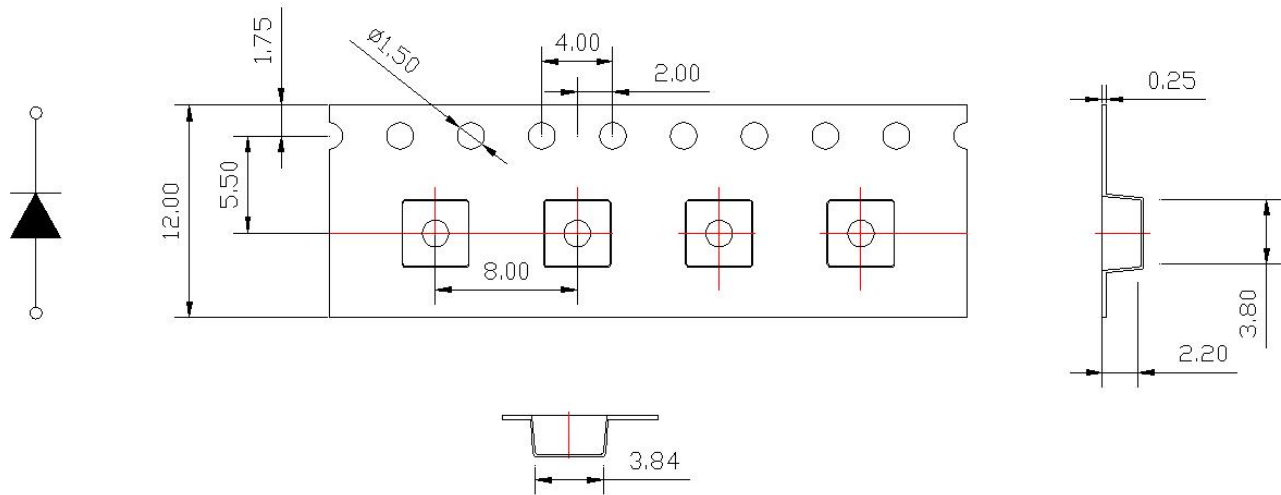

Reel Specifications

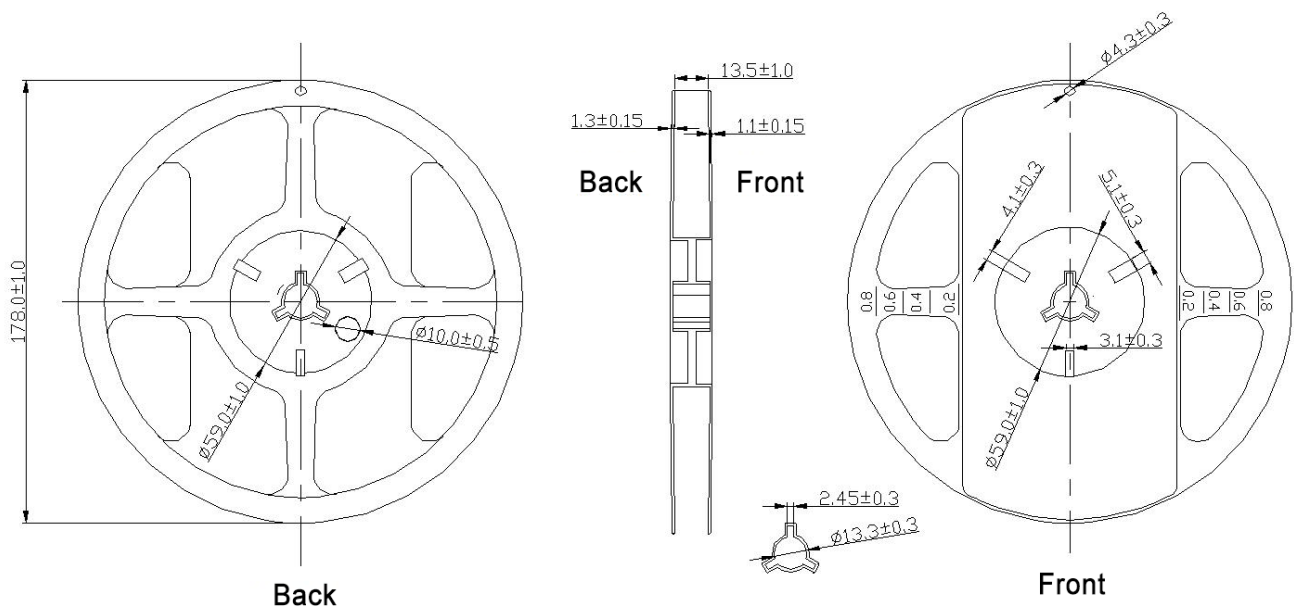

Technical Data Sheet

Label

SHENZHEN RAYMATES ELECTRONIC CO., LTD.	
Item No : XX-XXXX-XXXXX-XXXX	
IF (mA) :	VF (V) :
P (mW) :	λ_p (nm) :
Color Temp. Range:	Reflow Soldering Temp:
PCS: XXX	Order No :
 XXXXXXXXXXXXXXXXXX	

IF (mA) : _____

VF (V) : _____

P (mW) : _____

λ_p (nm) : _____

PCS: _____

Moisture Resistant Packaging

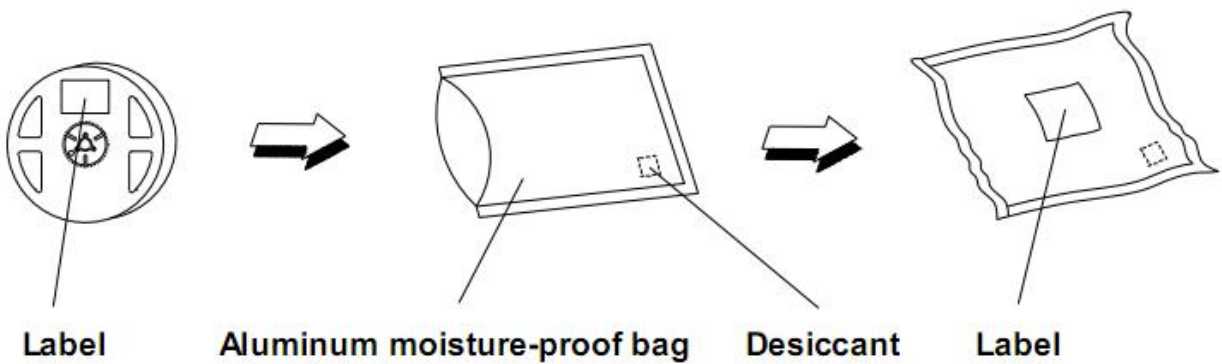

Technical Data Sheet

■ Product specification

1、 Storage/use :

(1) In order to avoid moisture absorption, it is suggested to store the products in a drying cabinet with desiccant. The storage temperature is $5^{\circ}\text{C}\sim 30^{\circ}\text{C}$, and the humidity is $\leq 60\% \text{HR}$

(2) After storage for six months, it is recommended to re-use the spectral separation to prevent changes in photoelectric parameters

(3) It is recommended to dry products that have been sealed and stored for more than six months before use. The drying condition is $65^{\circ}\text{C}\pm 5^{\circ}\text{C}$ for 10 hours

(4) The product shall be used within 24h after opening, otherwise it shall be baked at 65°C for 4-6h before reflow welding

(5) Do not press the lens surface with any sharp object (such as tweezers). Do not leave fingerprints on the surface of the lens. The positive normal pressure of the lens body should be less than 2 newtons, and The Times of press should be less than 3 times. The lateral pressure of the lens body is less than 1.5 newtons and the number of press is less than 3 times. Pick up materials correctly (as shown below)

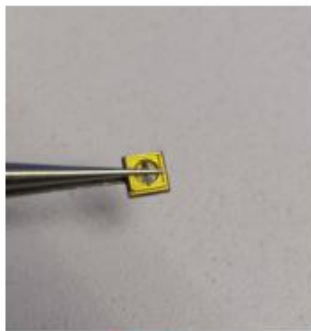

NG

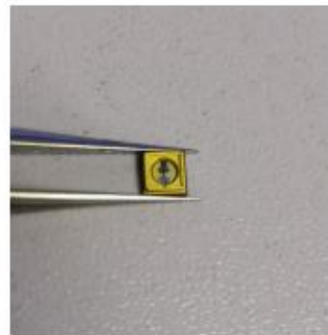

OK

- 2、 Products should not be in contact with water, oil or organic solutions.
- 3、 The operating current value of the product should consider LED junction temperature
- 4、 Repackage unused products in moisture-proof bags and store in a dry place
- 5、 External dimensions are subject to change without prior notice

Technical Data Sheet

6、 Anti-static requirements: when using products, must wear anti-static ring or anti-static gloves, all equipment, devices, machines must be effectively grounded. This product belongs to electrostatic sensitive device, pay attention to anti-static protection!

7、When LED working, push the temperature of PCB board should not exceed 60°C.

8、 Anti - vulcanization, chlorination, bromination and other treatments

In the closed, high temperature environment, the lamp may contain sulfur/chlorine/bromine and other substances, these sulfur, chlorine and bromine elements will volatilize into gas and corrosion LED light source. Because the LED seal silica gel has porous structure, and the light source silver plating reaction occurred. After curing reaction of LED light source, the functional area of the product will darken, the luminous flux will gradually decline until it becomes slightly bright, and the color temperature will drift obviously, and the LED light source will eventually fail. It is recommended to conduct sulfur emission test of lamps first to ensure that LED light source works in sulfur-free/chlorine/bromine and other material environment.

9、 Important safety tips

This product will emit deep ultraviolet ray when properly operated and electrified. Direct exposure may cause harm to human skin and eyes. It is recommended to wear protective clothing, gloves and goggles during operation/use. Direct exposure to uv without protective measures or direct exposure to uv is strictly prohibited.



10、 When the customer applies LED, it shall refer to the parameters of this specification and the requirements of operating environment. If the LED is used beyond the parameters or standard conditions without verification, our company will not make any quality guarantee.